

END OF RAILING ELEVATION

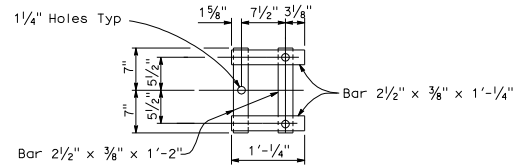

WALL ANCHOR PLATE DETAIL

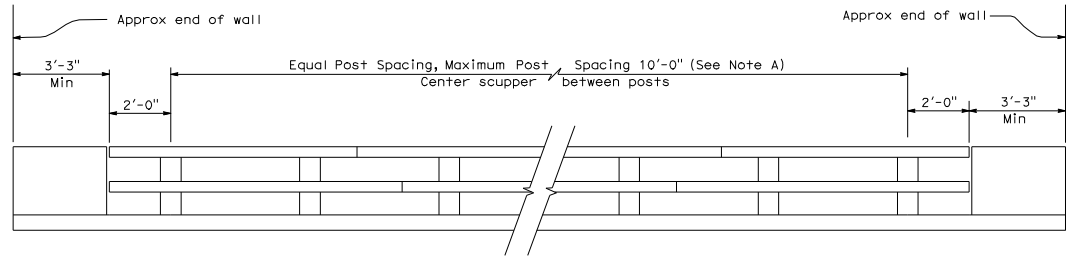

BRIDGE RAILING ELEVATION

**NOTE A:**  
Post spacing and/or block length to be adjusted to fit bridge length or wingwall length.

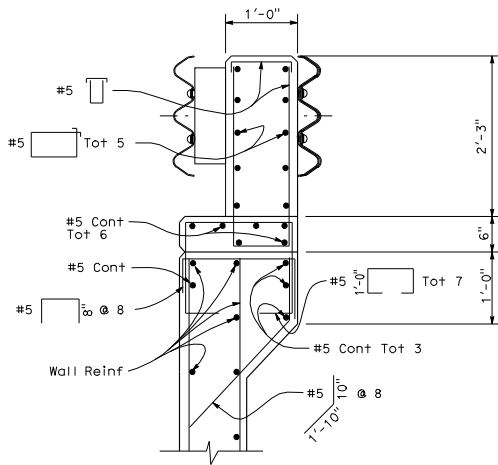

SECTION D-D

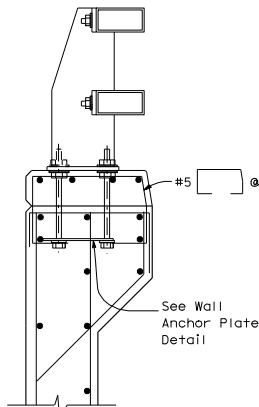

SECTION E-E  
Reinf same as for Section D-D except as noted.

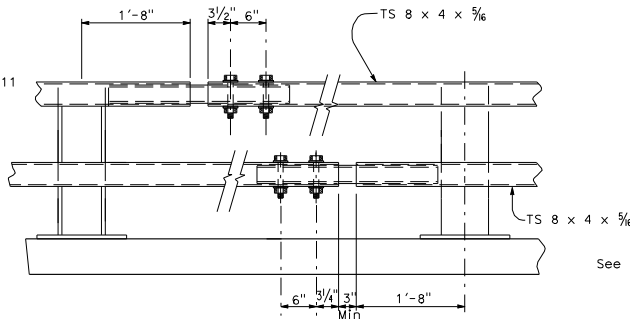

EXPANSION SPLICE

**NOTE B:**  
Use 3/4"  $\phi$  x 5 1/8" HS bolts with washers, fully tensioned. 1" holes in rail Typ

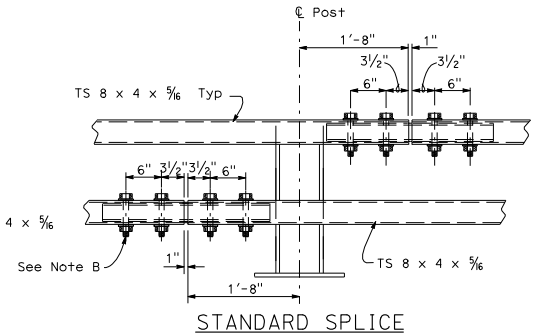

STANDARD SPLICE

STATE OF CALIFORNIA  
DEPARTMENT OF TRANSPORTATION  
**CALIFORNIA ST-10  
BRIDGE RAIL  
(SHEET 3 OF 3)**

NO SCALE

**B11-70**

DIST	COUNTY	ROUTE	POST MILES TOTAL PROJECT	SHEET NO.	TOTAL SHEETS

REGISTERED CIVIL ENGINEER

Tillot Satter

No. C42892

PLANS APPROVAL DATE

Exp. 03-31-08

CIVIL

STATE OF CALIFORNIA

The State of California or its officers or agents shall not be responsible for the accuracy or completeness of electronic copies of this plan sheet.

To get to the Caltrans web site, go to <http://www.dot.ca.gov>